

## Panasonic Etherea AC units to KNX Interface with Binary Inputs

Item number: INKNXPAN001I000

The Panasonic-KNX interface allows full bidirectional communication between Panasonic Etherea air conditioner units and KNX installations. It has four potential-free binary inputs to integrate external devices (such as window contacts or presence detectors), with the corresponding internal functions available to help improve energy efficiency.

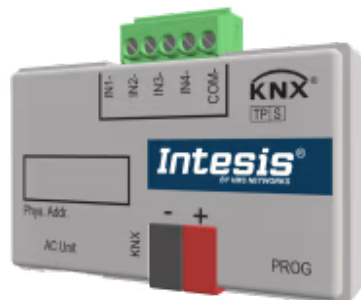

*Panasonic to KNX - 1 indoor unit*

### Features and benefits

- ✓ **ETS configuration**  
The interface is configured using the ETS standard configuration tool software.
- ✓ **Multiple energy efficiency functions available**  
Timeout, open window, or occupancy energy-saving functions are available to reduce energy costs.
- ✓ **Total unit control and monitoring from KNX**  
Through internal variables, running hours counter (for maintenance purposes), and error indication.
- ✓ **AC unit control by both remote controller and KNX**  
The AC unit can be simultaneously controlled by the manufacturer's remote controller and KNX.
- ✓ **Compatible with all KNX thermostats in the market**  
All the required DPT objects to be compatible with all KNX thermostats in the market are available.
- ✓ **Smooth KNX thermostat integration**  
KNX thermostats are allowed to control the AC unit via the thermostat's temperature sensor.
- ✓ **Up to five scenes saved/executed from KNX**  
Up to five scenes can be saved and executed from KNX.
- ✓ **Compact dimensions, allowing inside installation**  
The interface can be quickly installed inside the AC unit thanks to its reduced dimensions.

# Panasonic Etherea AC units to KNX Interface with Binary Inputs



## General

Net Width (mm)	59
Net Height (mm)	45
Net Depth (mm)	21
Net Weight (g)	100
Operating Temperature °C Min	0
Operating Temperature °C Max	60
Input Voltage (V)	From the AC unit.
Power Connector	Other
Capacity	1 indoor unit.
Installation Conditions	This gateway is designed to be mounted inside an enclosure. If the unit is mounted outside an enclosure, precautions should always be taken to prevent electrostatic discharge to the unit. When working inside an enclosure (e.g., making adjustments, setting switches, etc.), typical anti-static precautions should always be followed before touching the unit.
Content of Delivery	Intesis Gateway, Installation Manual, AC Connection cable.
Housing Materials	Plastic
Warranty (years)	3 years
Packaging Material	Cardboard

## Identification and Status

Product ID	INKNXPAN001I000
Country of Origin	Spain
HS Code	8517620000
Export Control Classification Number (ECCN)	EAR99

## Certifications and Standards

ETIM Classification	EC001604
---------------------	----------

# Panasonic Ethersea AC units to KNX Interface with Binary Inputs



## Certifications and Standards

WEEE Category

IT and telecommunications equipment



## Use Case

**Panasonic**

**KNX**

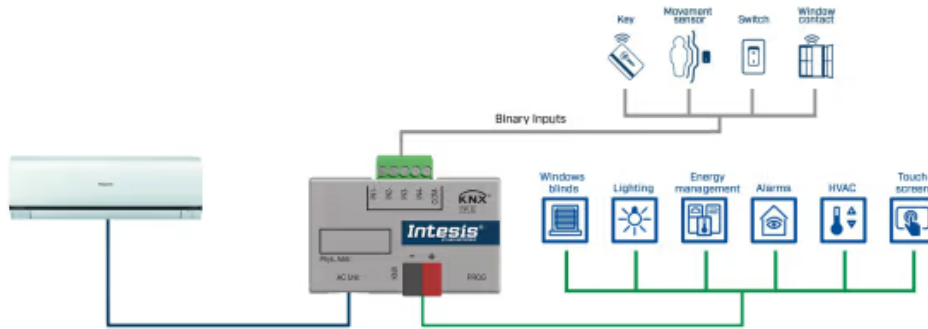

Integration example.