

Midea Commercial & VRF systems to Modbus TCP/RTU Application

Item number: IN770AIRXXSO000

The Midea application has been specially designed to allow bidirectional control and monitoring of Midea Commercial and VRF systems from a BMS, SCADA, PLC, or any other device working as a Modbus client. The solution allows the integration of up to 4 indoor units from a single interface.



Midea to Modbus TCP/RTU - Up to 4 Indoor Units

Features and benefits

- ✓ **Simultaneous Modbus TCP and RTU management**
The gateway can manage both Modbus TCP and Modbus RTU simultaneously.
- ✓ **Reduce commissioning time**
Scan the bus and find all the units connected to the VRF system with their control signals. Now, the Midea gateway provides signals from the outdoor units as well.
- ✓ **A gateway for any project's size**
Choose the license that better fits your needs (XXS - 4 indoor units, S - 16 indoor units, M - 64 indoor units), or upgrade your current license. Your project's dimensions and your budget are covered.
- ✓ **Fast and intuitive project configuration**
Intesis MAPS is the user-friendly, in-house-developed configuration tool that enables you to maximize the potential of Intesis gateways. Simply select your template and eliminate the need for tedious manual signal mapping.
- ✓ **Minimize the use of installation materials, reduce the installation work**
The gateway is connected directly to the outdoor units' communication bus. One single gateway enables centralized access to the entire VRF system.
- ✓ **Enable energy efficiency by controlling the building's main consuming asset.**
The gateway's Power Estimation Algorithm allows you to estimate the energy consumption of each indoor unit present in the VRF system
- ✓ **Avoid compatibility issues**
This gateway is compatible with Midea V4, V6, and V8 series.
- ✓ **Automatic updates will keep your product high performing**
Both the Intesis MAPS configuration tool and the interface's firmware can receive automatic updates to improve the product's functionality.

Midea Commercial & VRF systems to Modbus TCP/RTU Application



General

Net Weight (g)	240
Packed Width (mm)	106
Packed Height (mm)	58
Packed Depth (mm)	90
Packed Weight (g)	310
Operating Temperature °C Min	0
Operating Temperature °C Max	60
Capacity	Up to 4 indoor units.
Installation Conditions	This gateway is designed to be mounted inside an enclosure. If the unit is mounted outside an enclosure, precautions should always be taken to prevent electrostatic discharge to the unit. When working inside an enclosure (e.g., making adjustments, setting switches, etc.), typical anti-static precautions should always be followed before touching the unit.
AC Model Compatibility	This gateway is compatible with Midea V4, V6, and V8 series.
Content of Delivery	Intesis Gateway, Installation Manual, USB Configuration cable.
Not Included (in delivery)	Power supply not included.
Mounting	DIN rail mount (bracket included), Wall mount
Housing Materials	Plastic
Packaging Material	Cardboard
Warranty (years)	3 years

Identification and Status

Product ID	IN770AIRXXSO000_MBS_MID
Country of Origin	Spain
HS Code	8517620000

Midea Commercial & VRF systems to Modbus TCP/RTU Application



Identification and Status

Export Control Classification Number (ECCN)	EAR99
Purchasing Multiple ERP	1

Physical Features

LED Indicators	Gateway and communication status.
Push Buttons	Factory reset. I-Am message (for BACnet only). Normal mode/programming mode switch (for KNX only).

Certifications and Standards

ETIM Classification	EC001604
WEEE Category	IT and telecommunications equipment

Midea Commercial & VRF systems to Modbus TCP/RTU Application



Use Case

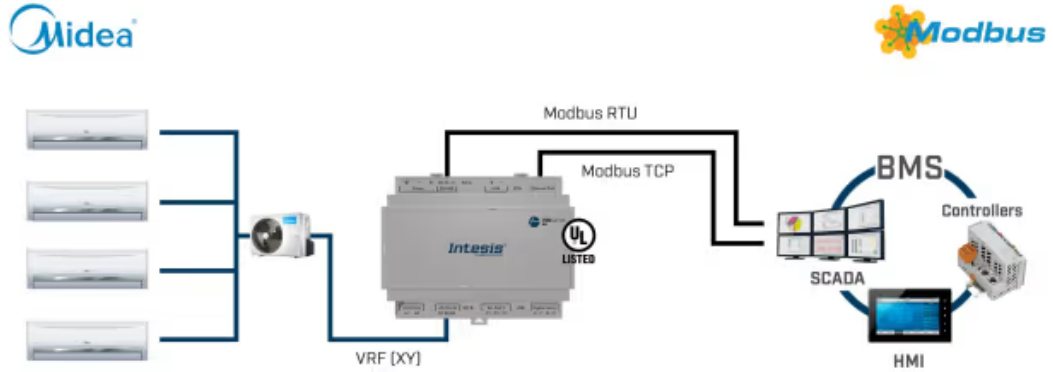

Integration example.



Use Intesis MAPS to change the protocol: BACnet, Modbus, KNX, or Home Automation