

Mitsubishi Electric City Multi systems to Modbus TCP/RTU Application

Item number: IN770AIR00S0000

The Mitsubishi Electric application has been specially designed to allow bidirectional control and monitoring of Mitsubishi Electric City Multi systems from a BMS, SCADA, PLC, or any other device working as a Modbus client. The solution allows the integration of up to 50 groups from a single interface.



Mitsubishi Electric to Modbus TCP/RTU - Up to 50 groups

Features and benefits

- ✓ **Simultaneous Modbus TCP and RTU management**
The gateway is a Modbus server and is able to manage both Modbus TCP and Modbus RTU simultaneously.
- ✓ **Automatic identification**
A scan function is available for automatic identification of the units present in the VRF system.
- ✓ **Individual indoor unit energy consumption signals**
Energy consumption signals from each indoor unit are available, so they can be checked individually.
- ✓ **Commissioning-friendly approach with Intesis MAPS**
Templates can be imported and reused as often as needed, significantly reducing commissioning time.
- ✓ **Direct access to the central controller**
Connection is simple, as the interface is directly connected to the central controller via Ethernet.
- ✓ **Outdoor unit signals**
Signals assigned to the outdoor unit are available to be used in the integration.
- ✓ **Multiple TCP client support**
The interface supports up to 6 TCP clients (incoming sockets).
- ✓ **Configuration tool and interface automatic updates**
Both the Intesis MAPS configuration tool and the interface's firmware can receive automatic updates.

Mitsubishi Electric City Multi systems to Modbus TCP/RTU Application



General	
Net Width (mm)	106
Net Height (mm)	58
Net Depth (mm)	90
Net Weight (g)	240
Packed Width (mm)	13
Packed Height (mm)	8.5
Packed Depth (mm)	14
Packed Weight (g)	310
Operating Temperature °C Min	0
Operating Temperature °C Max	60
Configuration	Intesis MAPS
Capacity	Up to 50 groups.
Installation Conditions	This gateway is designed to be mounted inside an enclosure. If the unit is mounted outside an enclosure, precautions should always be taken to prevent electrostatic discharge to the unit. When working inside an enclosure (e.g., making adjustments, setting switches, etc.), typical anti-static precautions should always be followed before touching the unit.
AC Model Compatibility	List of compatible centralized controllers: G-50, G-50A, GB-50A, GB-50ADA, AB-150, AE-200, AE-50, AG-150A, EW-50, EB-50GU.
Content of Delivery	Intesis Gateway, Installation Manual, USB Configuration cable.
Not Included (in delivery)	Power supply not included.
Mounting	DIN rail mount (bracket included), Wall mount
Housing Materials	Plastic
Warranty (years)	3 years

Mitsubishi Electric City Multi systems to Modbus TCP/RTU Application



General

Packaging Material	Cardboard
--------------------	-----------

Identification and Status

Product ID	IN770AIR00SO000_MBS_MIT
------------	-------------------------

Country of Origin	Spain
-------------------	-------

HS Code	8517620000
---------	------------

Export Control Classification Number (ECCN)	EAR99
---	-------

Physical Features

LED Indicators	Gateway and communication status.
----------------	-----------------------------------

Push Buttons	Factory reset. I-Am message (for BACnet only). Normal mode/programming mode switch (for KNX only).
--------------	--

Certifications and Standards

ETIM Classification	EC001604
---------------------	----------

WEEE Category	IT and telecommunications equipment
---------------	-------------------------------------

Mitsubishi Electric City Multi systems to Modbus TCP/RTU Application



Use Case

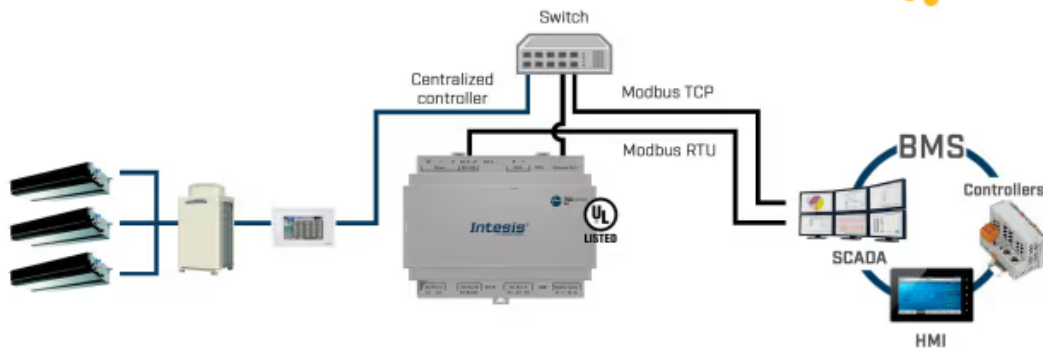

Integration example.

Mitsubishi Electric City Multi systems to Modbus TCP/RTU Application



Use Case





Use Intesis MAPS to change the protocol: BACnet, Modbus, KNX, or Home Automation