

EtherNet/IP - BACnet/IP & MS/TP Server Gateway

Item number: INBACEIP1K20000

The Intesis BACnet-EtherNet/IP gateway allows you to seamlessly interconnect PLC/BMS systems and their connected devices between BACnet/IP and MS/TP control systems and EtherNet/IP networks. The gateway's BACnet side acts as a BACnet server and the EtherNet/IP side as an EtherNet/IP adapter and is configured via the Intesis MAPS configuration tool.



EtherNet/IP to BACnet/IP & MS/TP - 1200 points

Features and benefits

- ✓ **Support for BACnet/IP or BACnet MS/TP server**
BACnet/IP (via Ethernet) or BACnet MS/TP (via EIA-485) server connection options are supported.
- ✓ **BACnet Advanced features - calendars, schedules...**
BACnet's advanced features, such as calendars, trend logs, schedules, and more, are available.
- ✓ **EtherNet/IP adapter interface (Anybus technology)**
The gateway uses Ethernet/IP Anybus technology, which uses the award-winning NP40 network processor.
- ✓ **Control and monitoring over EtherNet/IP scanners**
The gateway acts as an Ethernet/IP adapter, being monitored and controlled by EtherNet/IP scanners.
- ✓ **Configuration tool and gateway's automatic updates**
Both the Intesis MAPS configuration tool and the gateway's firmware can receive automatic updates.

EtherNet/IP - BACnet/IP & MS/TP Server Gateway



General	
Net Width (mm)	106
Net Height (mm)	58
Net Depth (mm)	90
Net Weight (g)	289
Packed Width (mm)	197
Packed Height (mm)	85
Packed Depth (mm)	120
Packed Weight (g)	451
Capacity	Up to 1200 points.
Installation Conditions	This gateway is designed to be mounted inside an enclosure. If the unit is mounted outside an enclosure, precautions should always be taken to prevent electrostatic discharge to the unit. When working inside an enclosure (e.g., making adjustments, setting switches, etc.), typical anti-static precautions should always be followed before touching the unit.
Content of Delivery	Intesis Gateway, Installation Manual, USB Configuration cable.
Not Included (in delivery)	Power supply not included.
Mounting	DIN rail mount (bracket included)
Housing Materials	Plastic
Warranty (years)	3 years
Packaging Material	Cardboard

Identification and Status	
Product ID	INBACEIP1K20000
Country of Origin	Spain
HS Code	8517620000

EtherNet/IP - BACnet/IP & MS/TP Server Gateway



Identification and Status

Export Control Classification Number (ECCN)	EAR99
Purchasing Multiple ERP	1

Physical Features

LED Indicators	Gateway and communication status.
Push Buttons	Sends to Broadcast I-Am message.
Battery Description	Manganese Dioxide Lithium button battery.

Certifications and Standards

ETIM Classification	EC001604
WEEE Category	IT and telecommunications equipment



Use Case

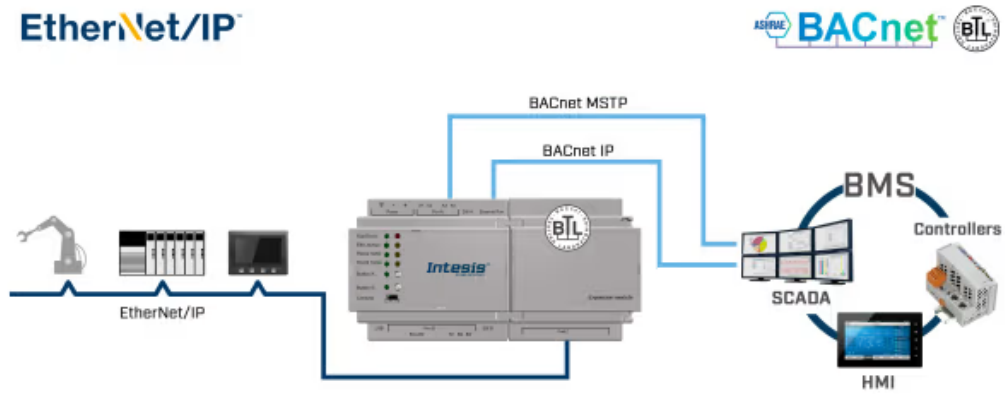

Integration example.